



O-RAN Software Portfolio

All things wireless ●



Open RAN App Provider Training & Consulting Partner

Rimedo Labs specializes in providing high-quality consulting, implementation, and R&D services in Open RAN, 5G, and 6G. We are a spin-off from the Poznan University of Technology, Poland, from the Institute of Radiocommunications.

Our services in the **Open RAN** area include:

- **xApp and rApp development** for the RAN Intelligent Controller;
- Pre-recorded and Live **technical courses** delivery;
- **Live webinars**;
- Dedicated **simulations** and **algorithm design**;
- **Whitepapers** and **technical articles** delivery.

Rimedo Labs is an **O-RAN Alliance**, **AI-RAN Alliance**, **Ericsson Intelligent Automation Platform** and **Nokia SMO Marketplace** member, and **Amdocs** and **Keysight** technology partner.



Rimedo Labs xApp/rApp Portfolio

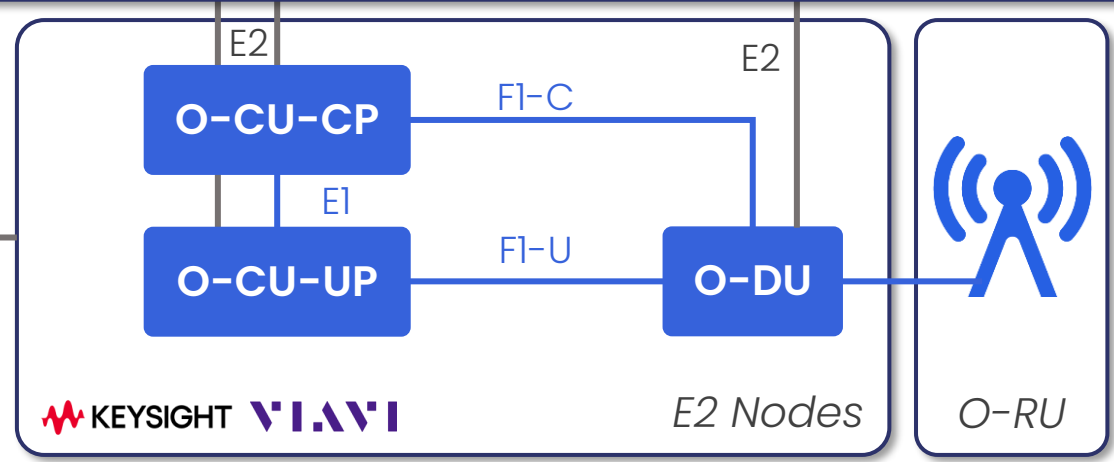
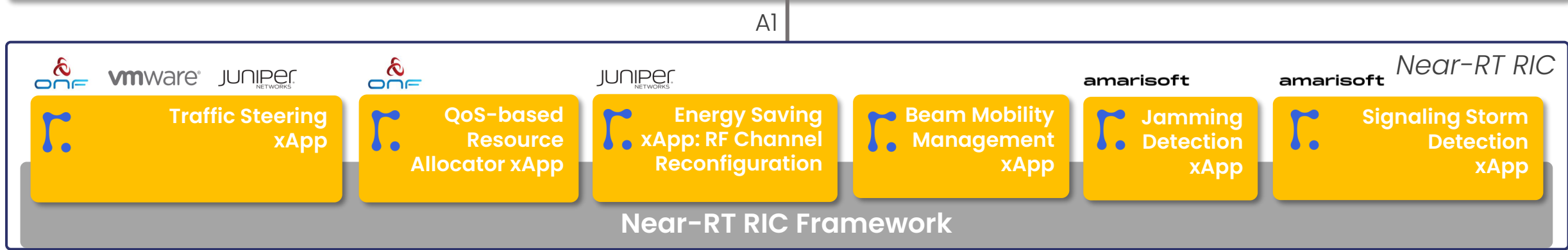
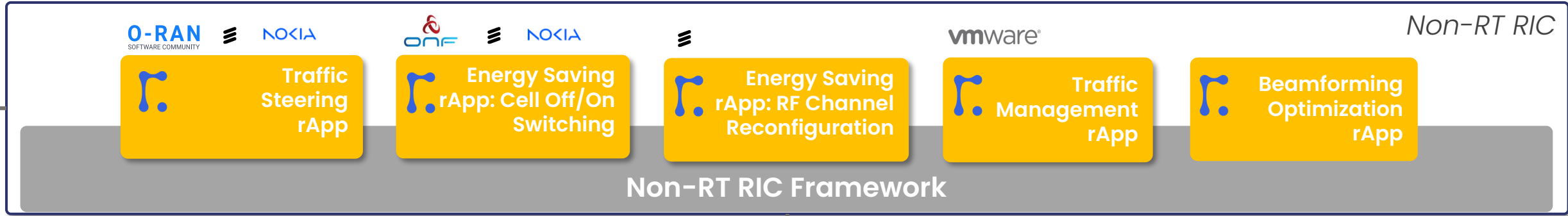

O1



Rimedo Labs rApps

Traffic Steering *rApp*

Traffic Steering *rApp* (TM-*rApp*) enables intelligent traffic distribution achieving balanced load across cells and improved cell user performance. The *rApp* collects information about cell configuration, bandwidth and load and updates the offsets between cells effectively modifying their coverage. As a result, even if some users are directed to cells with slightly worse radio conditions, a better radio resource utilization is achieved, maximizing overall network efficiency.

Key features:

- Performs load balancing between cells utilizing O1 interface
- Indirectly controls handovers through cell individual offsets
- Works for both 5G and 4G networks
- Integrated with OSC Non-RT RIC and verified with VIAVI network emulator

O-RAN Software Community (SC)

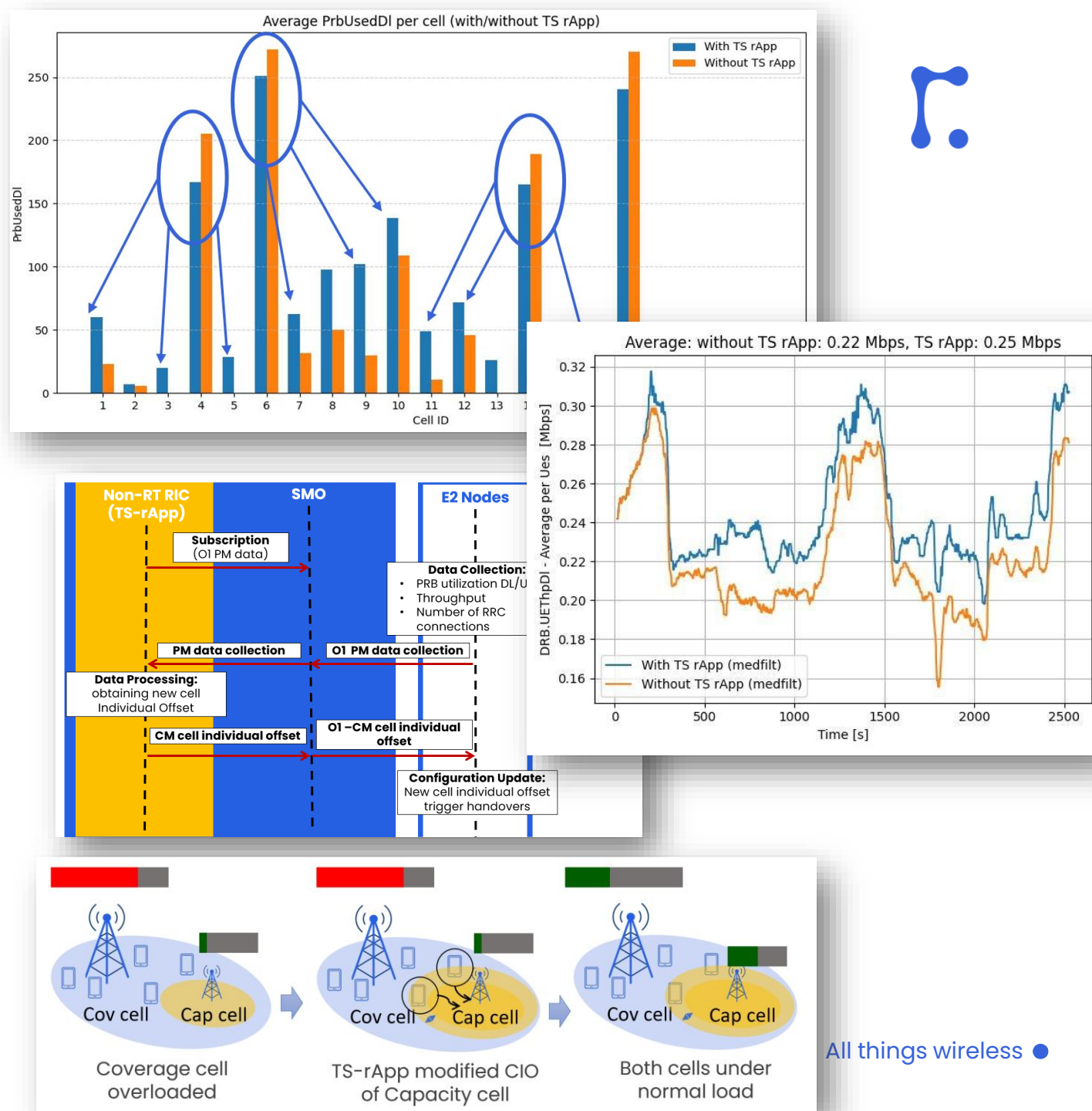

Energy Saving rApp: Cell Off/On Switching

Energy Saving rApp: Cell Off/On Switching (ES-rApp-COS)

enables the cell off/on switching to maximize energy efficiency. The rApp monitors the traffic load per cell, current power consumption, etc., over the O1 interface. Based on this the rApp generates appropriate traffic control policies and sends them to TS-xApp via the AI and orders capacity cells off/on over the O1 interface.

Key features:

- Switches off/on cells to maximize energy efficiency
- Controls Traffic Steering policies to distribute users for the remaining cells before cells are switched off
- Suitable for heterogeneous network scenarios
- Addresses Cell Off/On Switching use case from O-RAN ALLIANCE
- Integrated with ONF's SD-RAN and VMware's RIC

```

2023-06-22 11:11:21,767 - INFO - PRB usage: 0.159 (spectral efficiency: 3.792 bps/Hz)
(energy consumption: 0.90/0.90 W; per day: 21.60 Wh; per day savings: 0.00 Wh)

2023-06-22 11:11:22,269 - INFO - PRB usage: 0.151 (spectral efficiency: 3.776 bps/Hz)
(energy consumption: 0.90/0.90 W; per day: 21.60 Wh; per day savings: 0.00 Wh)

2023-06-22 11:11:22,770 - INFO - PRB usage: 0.144 (spectral efficiency: 3.760 bps/Hz)
(energy consumption: 0.90/0.90 W; per day: 21.60 Wh; per day savings: 0.00 Wh)

2023-06-22 11:11:22,770 - INFO - Disabling cell with id 2
2023-06-22 11:11:22,801 - INFO - Disabling cell with id 4
2023-06-22 11:11:22,832 - INFO - Disabling cell with id 3
2023-06-22 11:11:22,865 - INFO - Disabling cell with id 1
2023-06-22 11:11:23,392 - INFO - PRB usage: 0.696 (spectral efficiency: 17.720 bps/Hz)
(energy consumption: 0.30/0.90 W; per day: 7.20 Wh; per day savings: 14.40 Wh)

2023-06-22 11:11:23,893 - INFO - PRB usage: 0.693 (spectral efficiency: 15.680 bps/Hz)
(energy consumption: 0.30/0.90 W; per day: 7.20 Wh; per day savings: 14.40 Wh)
    
```

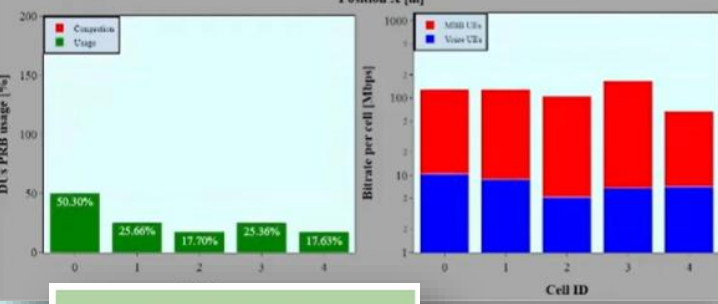
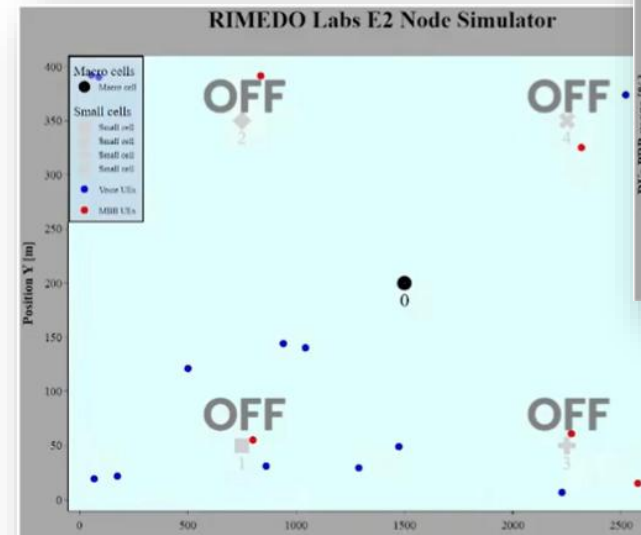
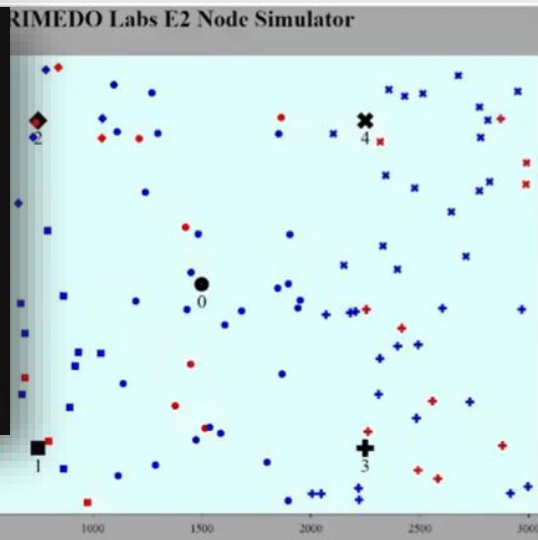

UEs with FIVE_QI = [0, 1]
FORBID
 Cells with CELL_ID = [1, 2, 3, 4]

UEs with FIVE_QI = [0, 1]
SHALL
 Cells with CELL_ID = [0]

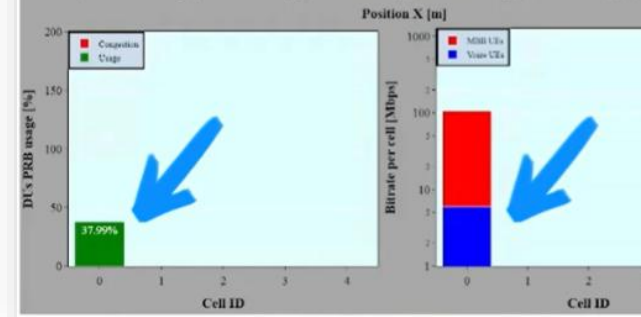

Energy Saving xApp/rApp: RF Channel Reconfiguration

Energy Saving xApp/rApp: RF-Channel Reconfiguration (ES-x/AppPrApp-RCR) enables an intelligent selection of RF Channel Reconfiguration to maximize energy efficiency. The rApp collects the traffic load per beam, throughput, the current power consumption, and the configuration of the antenna panel (e.g. 64, 32, or 16 antennas). Based on the ML model infers the proper antenna array configuration.

Key features:

- Scales up/down the antenna array to maximize energy efficiency
- Dedicated to Massive MIMO scenarios
- Utilizes Machine Learning inference
- Addresses RF Channel Reconfiguration use case from O-RAN ALLIANCE
- Can be deployed as xApp or rApp
- Integrated with Near-RT RIC from Juniper and verified with Keysight RICtest

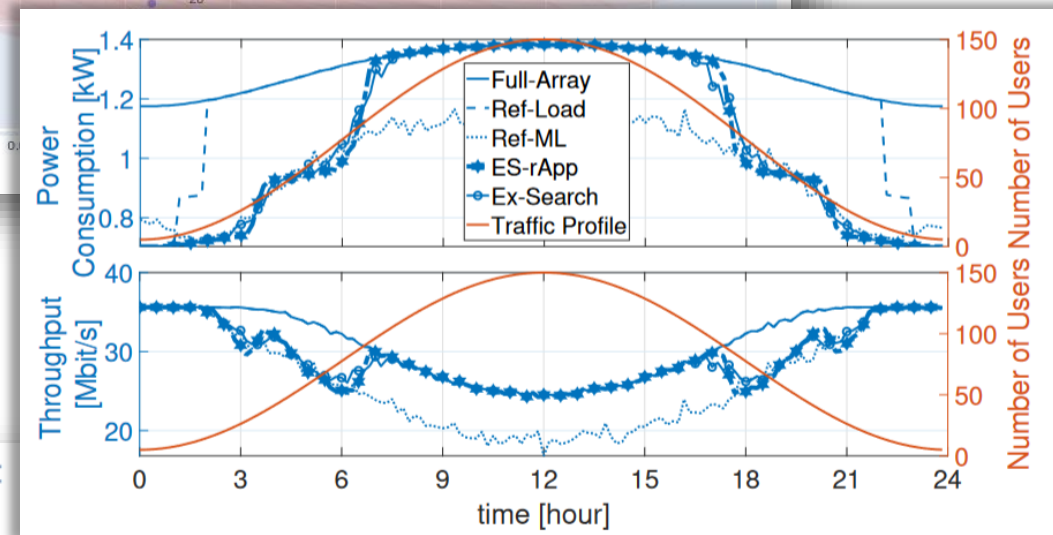
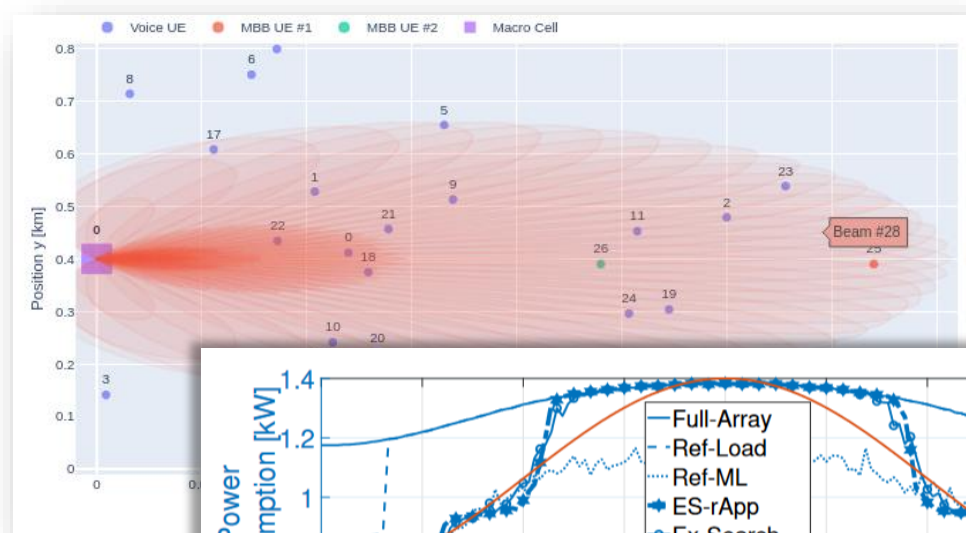

Energy Efficiency Statistics:

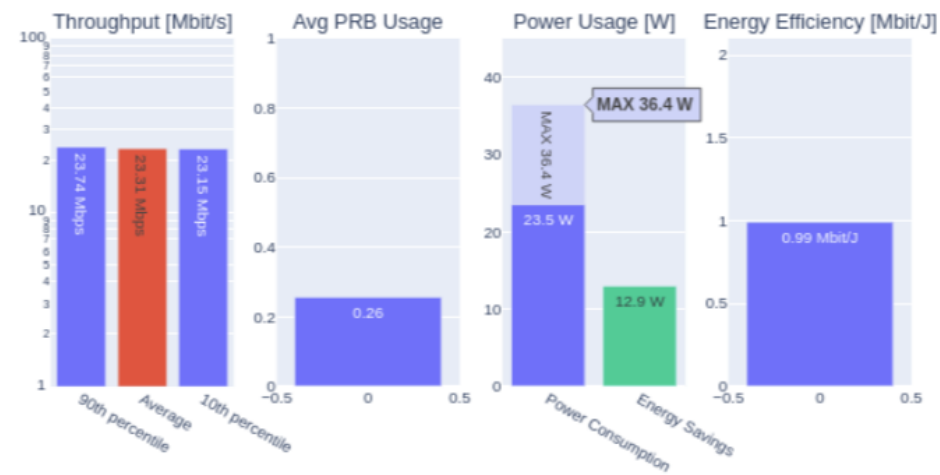

Traffic Management *rApp*



Traffic Management rApp (TM-rApp) enables intelligent traffic steering based on slices and device type. The rApp collects the location of devices, their types, requirements, and speed. When a network has enough available resources TM rApp tries to minimize time-critical traffic by minimalization of handovers. It is especially important in the case of emergency, autonomous platoons, and in general vehicular communication, where delay plays a key role.

Key features:

- Controls Traffic Steering policies, to optimize vehicular communication requirements
- Dedicated for V2N scenarios
- Extends Traffic Steering xApp logic
- Minimizes the number of handovers, thus reducing transmission delay
- Integrated with VMware's RIC

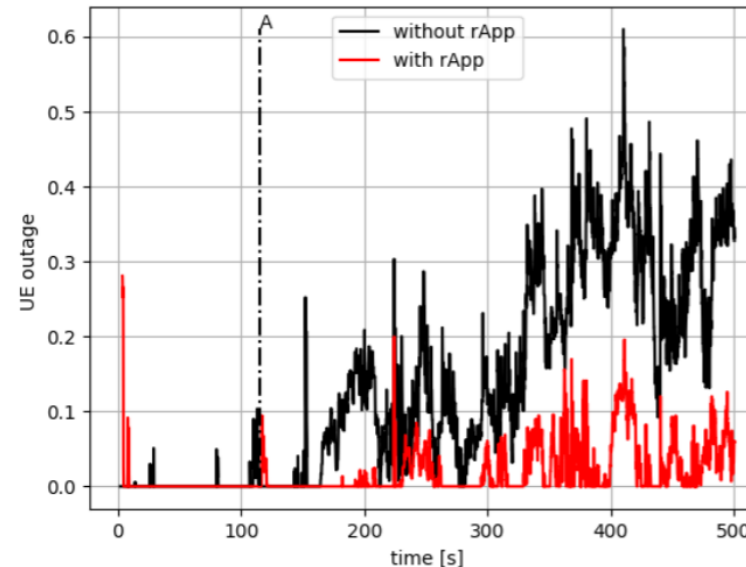
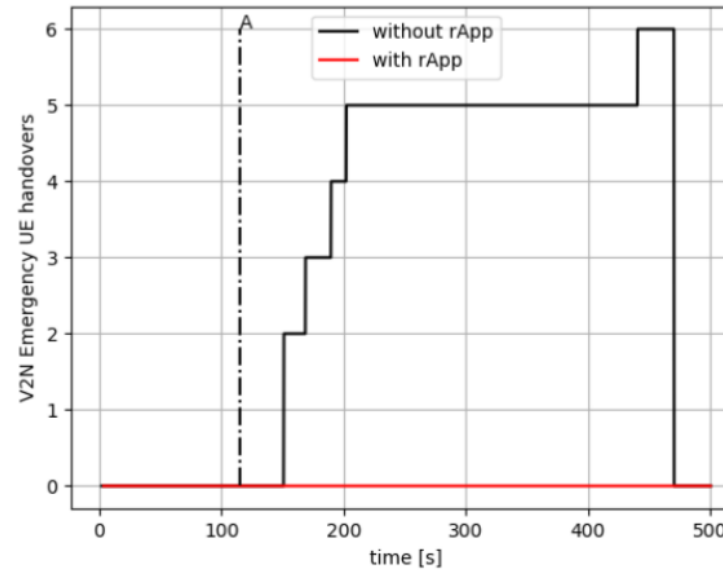

```
{
  "scope": {
    "sliceId": {
      "sst": 1234,
      "sd": "456DEF",
      "plmnId": {
        "mcc": "314",
        "mnc": "628"
      }
    },
    "qosId": {
      "5qi": 2
    }
  },
  "tspResources": [{
    "cellIdList": [{
      "plmnId": {
        "mcc": "314",
        "mnc": "628"
      },
      "cid": {
        "ncI": 43
      }
    }],
    "preference": "SHALL"
  }]
}
```

ORAN_TrafficSteeringPreference_2.0.0



Beamforming Optimization *rApp*



Beamforming Optimization *rApp* (BO-*rApp*)

dynamically adjusts Grid-of-Beams (GoB) azimuth and elevation patterns. Utilizing AI-driven analysis of UE SINR statistics, it aligns beam coverage with actual traffic distributions, maximizing spectral efficiency and cell-edge performance without manual intervention. The BO-*rApp* can work together with Rimedo Labs Digital Twin to fine-tune its AI/ML model and test new beam directions before applying them in a real RAN.

Key features:

- Suitable for Massive MIMO GoB
- Suitable for heterogeneous networks
- Maximizes SINR and spectral efficiency
- Enables automated coverage optimization
- Ready for AI/ML-based optimization
- Works for semi-static and dynamic scenarios

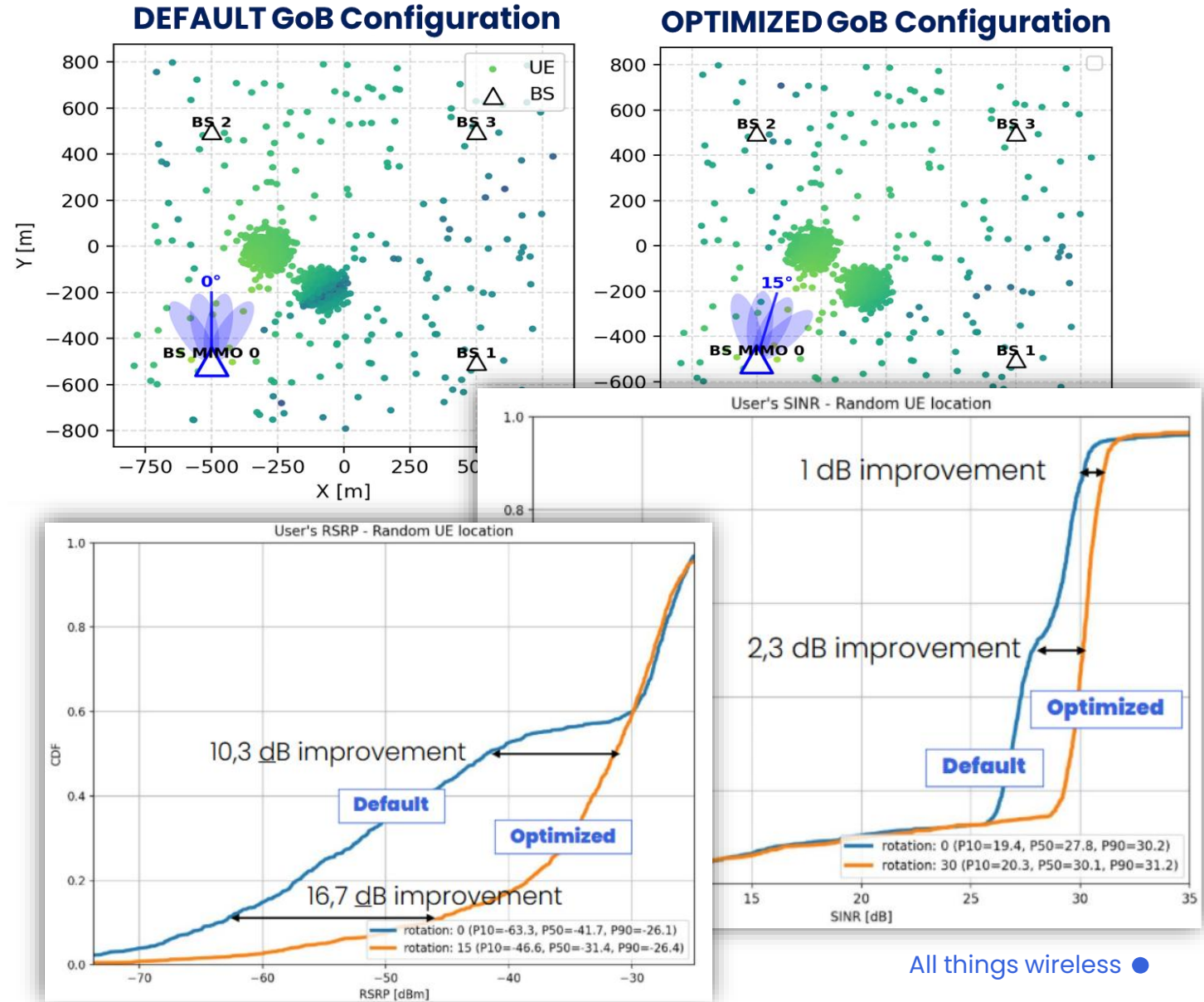



Rimedo Labs xApps

Traffic Steering xApp

Traffic Steering (TS) xApp associates the users with the Base Station taking into account user radio conditions, cell types, cell load, and service type/QoS profile. It can be controlled by policies from Non-RT RIC along with the ML model to properly allocate the policy.

Key features:

- Suitable for heterogeneous network scenarios
- Supports ES-rApp and TM-rApp
- Delivered together with ML model to optimize policy
- Per-user association decision taking into account radio conditions, service type, cell type
- Balances network load
- Can be integrated with ES-rApp, TM-rApp, and QRA-xApp
- Supports Mixed Reality traffic type (taking into account packet delay – MR-focused load balancing)
- Optimizes user throughput, cell outage or cell load
- Integrated with Near-RT RICs from ONF, VMware, and Juniper and verified with Keysight RICtest

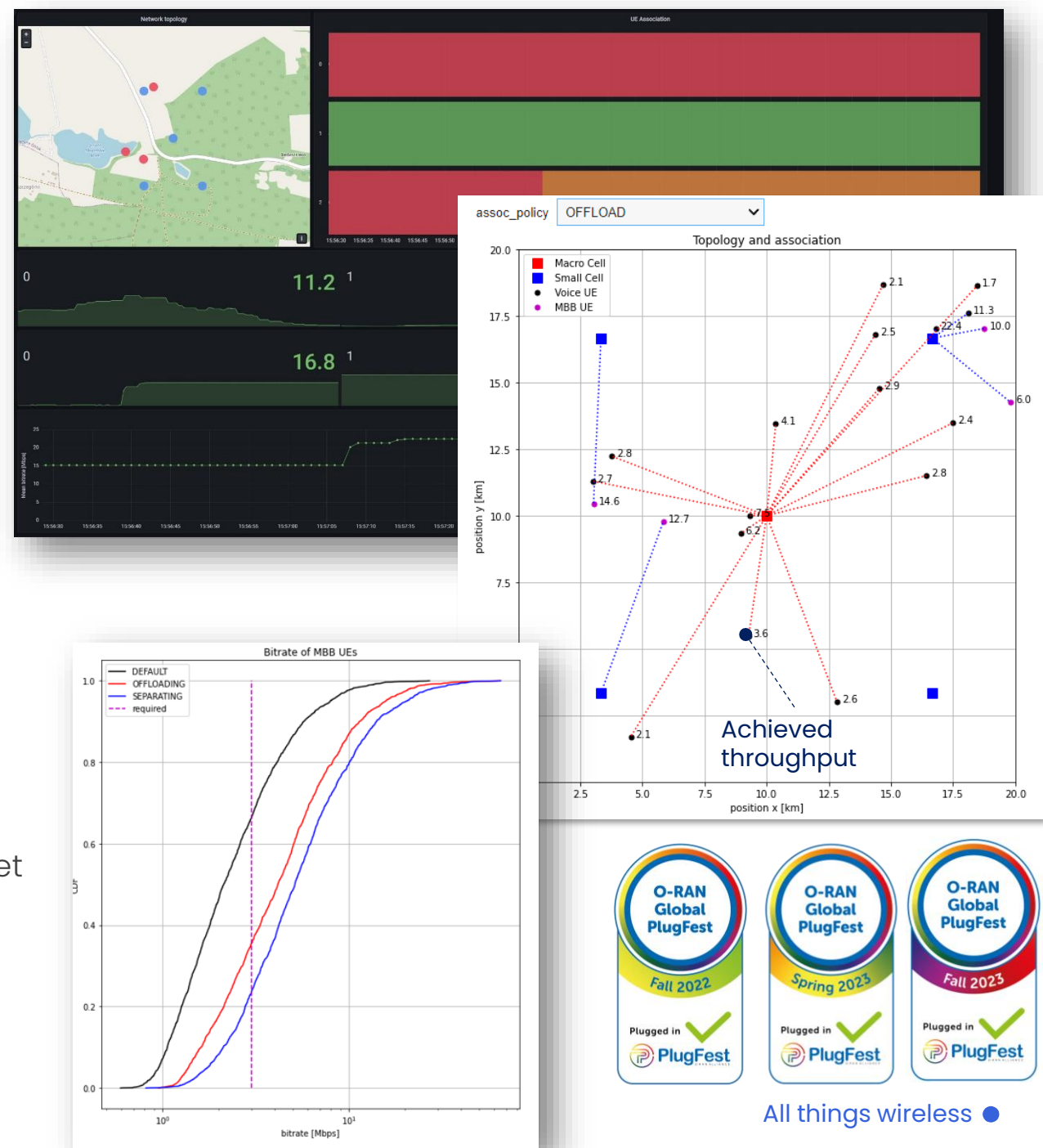

QoS-based Resource Allocator *xApp*



QoS-based Resource Allocator (QRA) xApp aims at splitting the radio resources between the network slices depending on their traffic characteristics, and Service Level Agreement (SLA) e.g., throughput demands. The network operator can use the QRA xApp to favor network slices serving various traffic types. Moreover, RRM rules can be formulated independently for individual cells, e.g., macro cells, small cells.

Key features:

- Splits Radio Resources between slices based on their traffic types, e.g., low latency Voice services, high throughput MBB services
- Adjusts Radio Resources to the SLA demands
- RRM decisions driven by policies from Non-RT RIC
- Optionally with an ML model
- Suitable for Heterogeneous Networks
- Can work in conjunction with TS xApp
- Integrated with ONF's SD-RAN

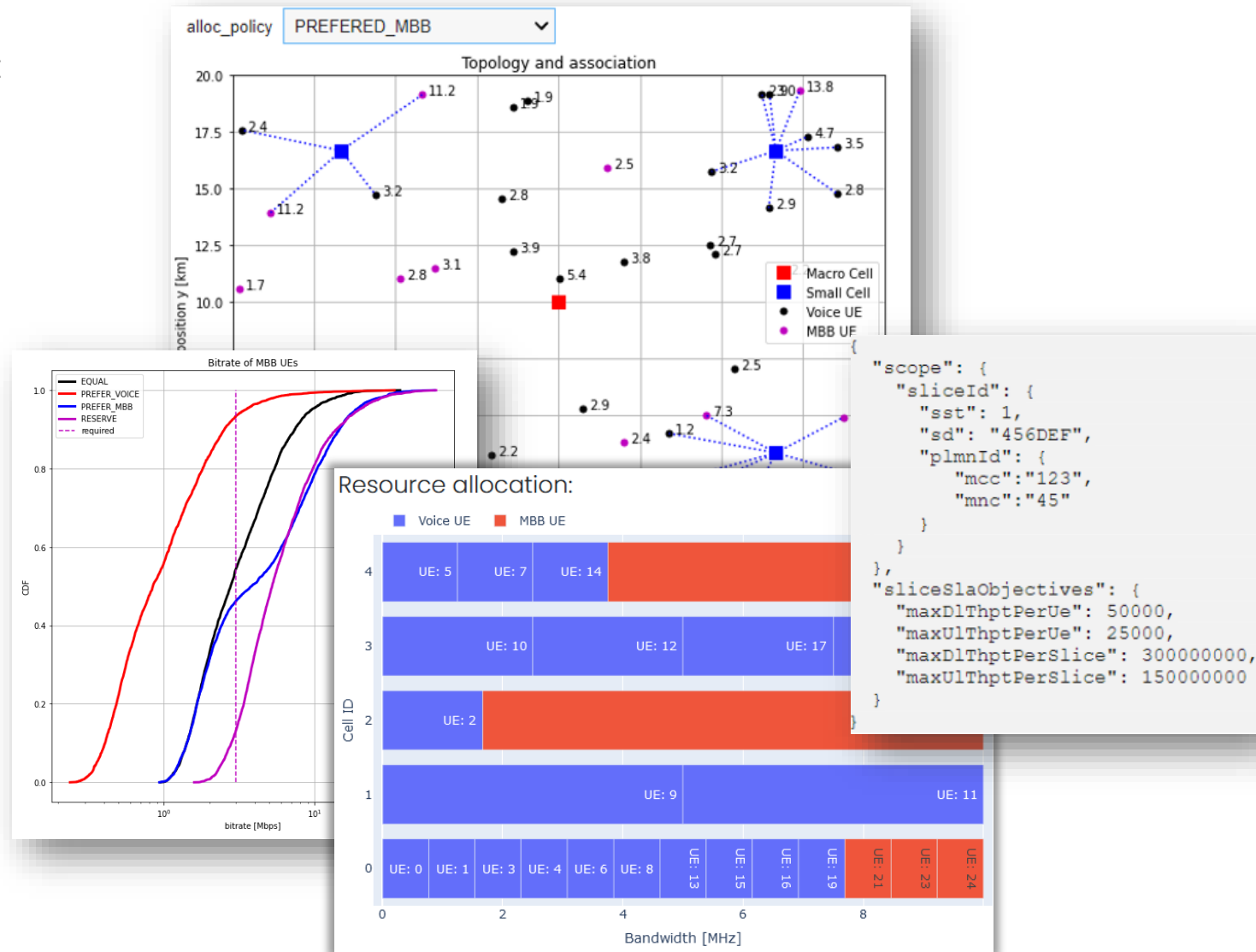

Beam Mobility Management *xApp*



Beam Mobility Management (BMM) *xApp* enables an intelligent selection of beams for mobile network users. The *xApp* collects per-beam RSRPs, tagged with measurement locations based on reports from UEs to create Radio Environment Maps. These are further used to train Machine Learning models, to achieve MNO's defined goals, e.g., minimization of beam reselection, or maximization of SNR.

Key features:

- Suitable for scenarios with high-mobility users, e.g., motorways, high-speed trains
- Dedicated to 5G Grid-of-Beams beamforming
- Utilizes Machine Learning inference
- Flexible goal definition, e.g., minimization of beam reselections, SNR maximization

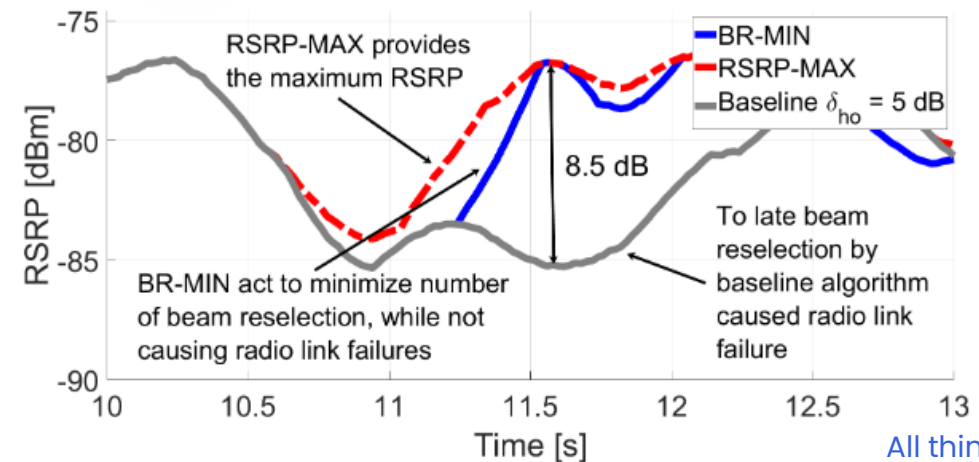
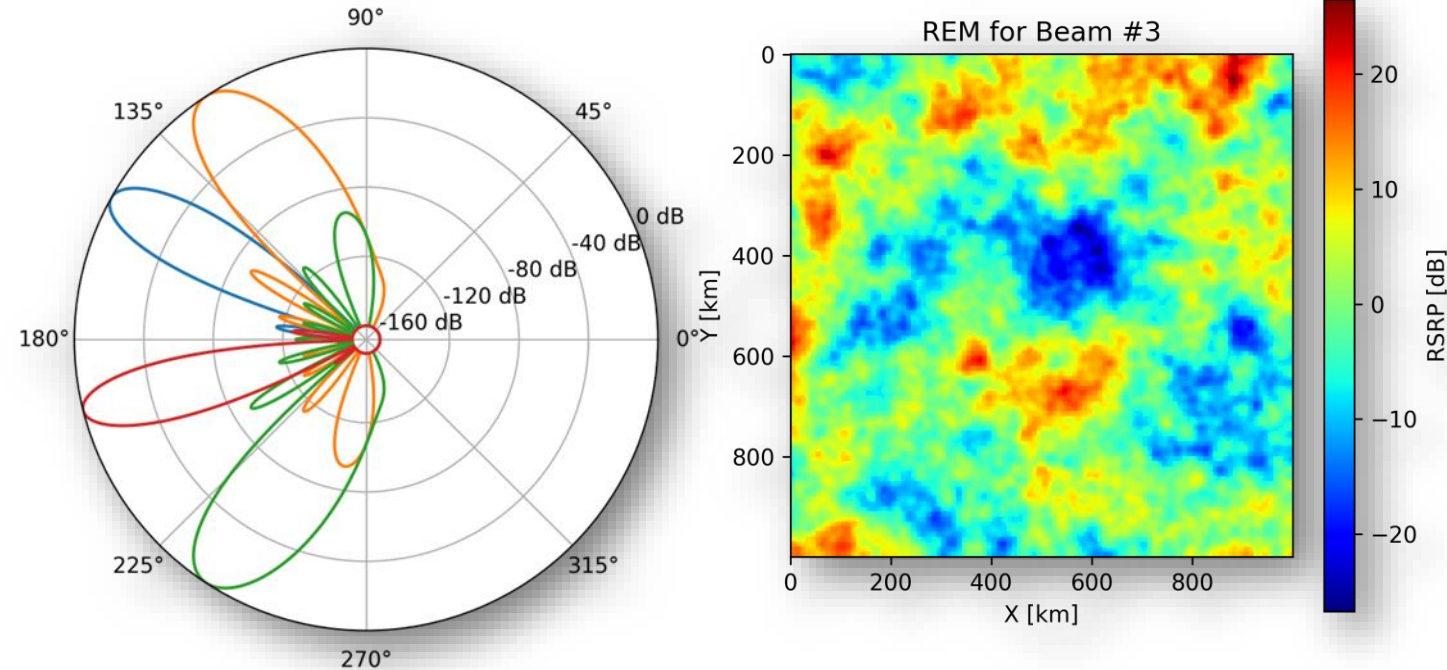

Jamming Detection xApp



Jamming Detection xApp (JD-xApp) detects the jamming based on user RSRP and CQI reports. xApp monitors the two-dimensional distribution of RSRP and CQI and analyzes it to detect abnormal patterns. If the jamming is detected, the xApp can lower the utilized Modulation and Coding Schemes to reduce the Block Error Rate (BLER).

Key features:

- Security threat detection at the RAN level
- Jamming detection based on CQI and RSRP reports obtained through the E2 interface
- Suitable for IIoT/URLLC scenarios
- When detecting jamming, preserves user BLER
- Verified under Amarisoft-based real testbed

amarisoft

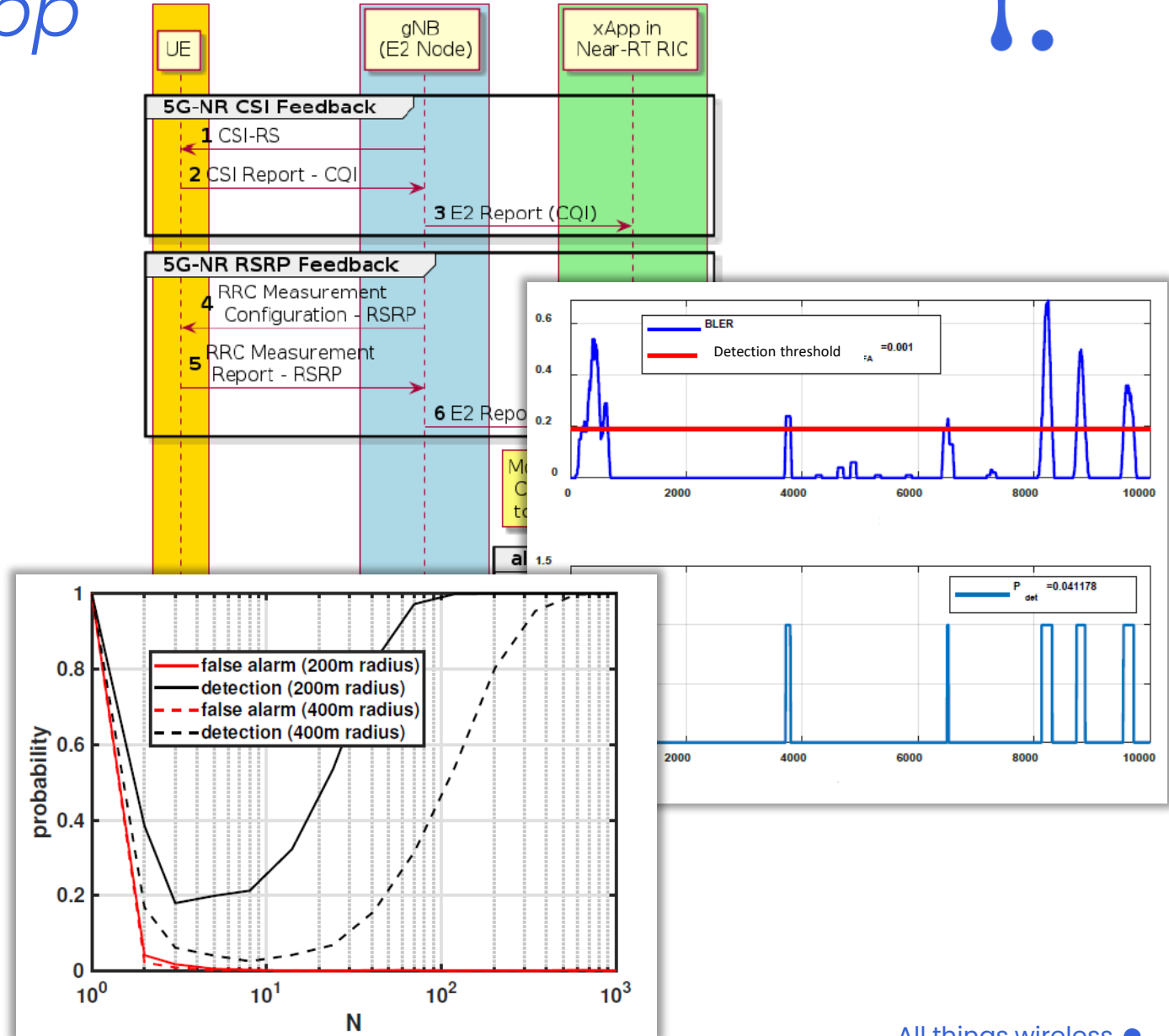

Signaling Storm Detection xApp



Signaling Storm Detection xApp (SSD-xApp)

prevents from Denial of Service attack conducted through the excessive sending of registration requests. The SSD-xApp monitors the Random Access Responses to build a KPI profile and filter adversaries based on their Timing Advance parameter at the early stage of registration, i.e., in RAN.

Key features:

- Security threat detection at the RAN level
- Signaling storm detection based on the analysis of Random Access Responses
- Suitable for IIoT scenarios
- Adversary registration requests can be filtered out by their TA and blocked at the stage of RAN.
- Addresses Signalling Storm Protection use case from O-RAN ALLIANCE
- Verified under Amarisoft-based real testbed

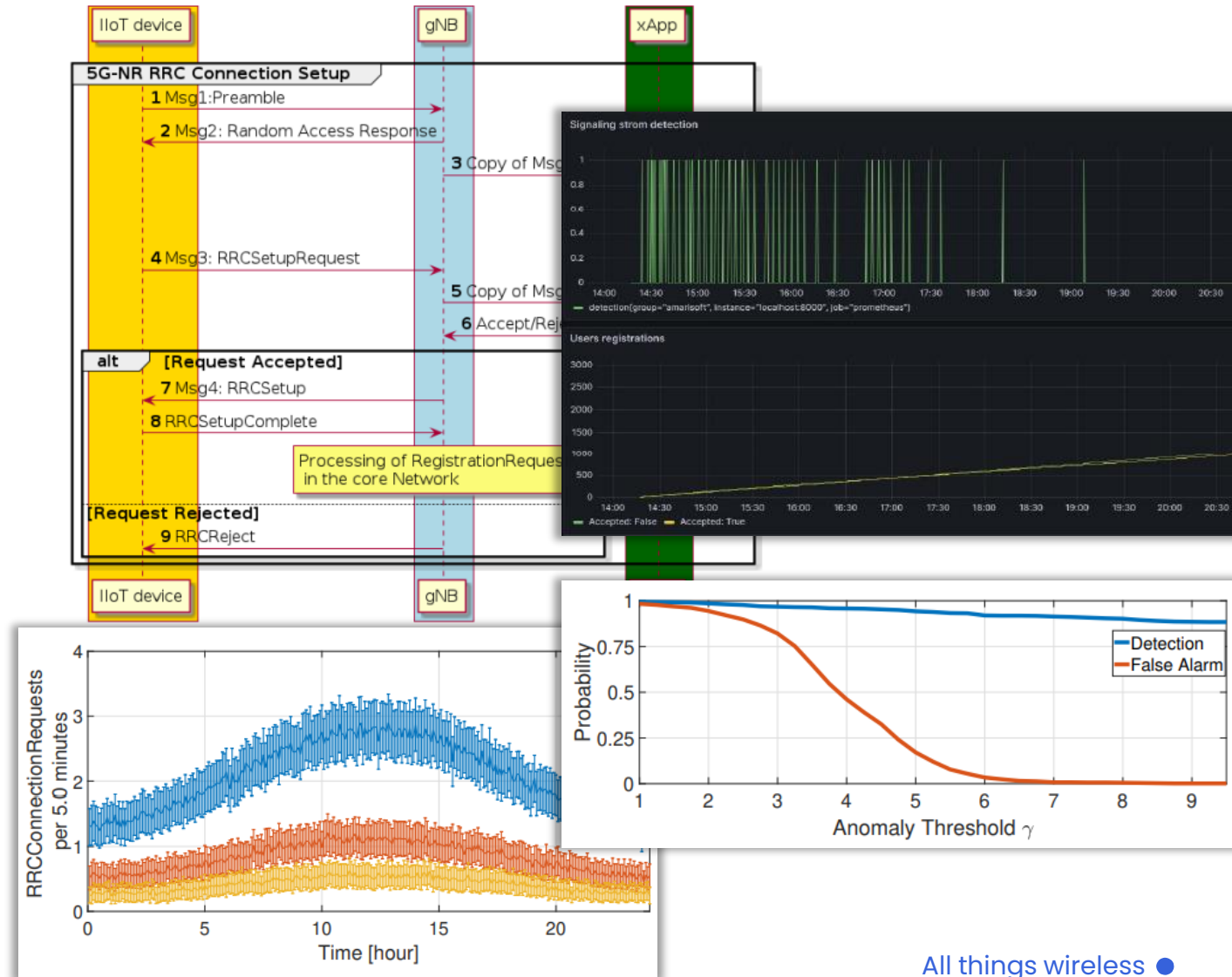



Example Use Cases

Example Use Cases



Energy saving for HetNet

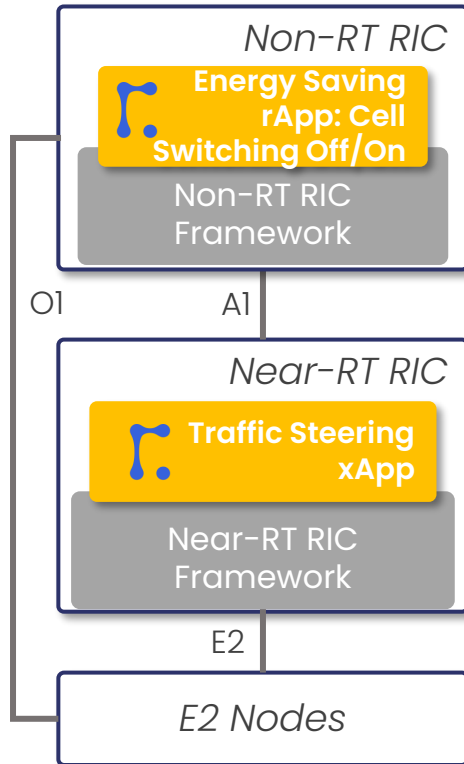

ES-rApp working in cooperation with TS-xApp through adjustment of TS policies. ES-rApp decides on cell on/off for the capacity-small-cell layer.

Energy saving for Massive MIMO

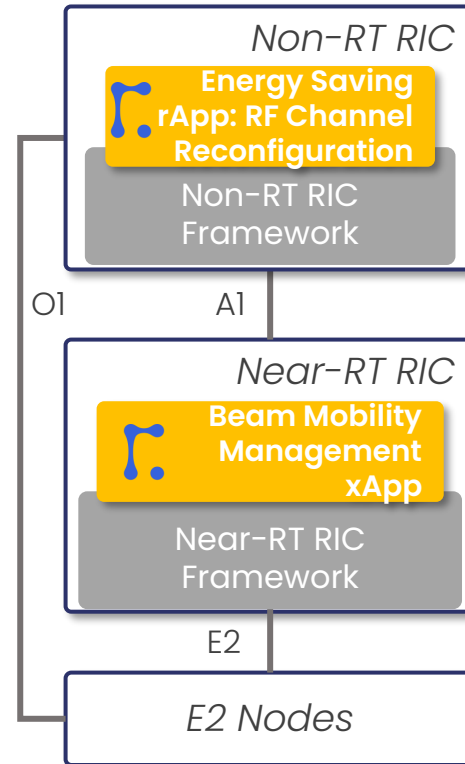

ES-rApp decides on the antenna panel configuration and updates the BMM-xApp with the configuration and REM.

Traffic Management for V2X scenarios

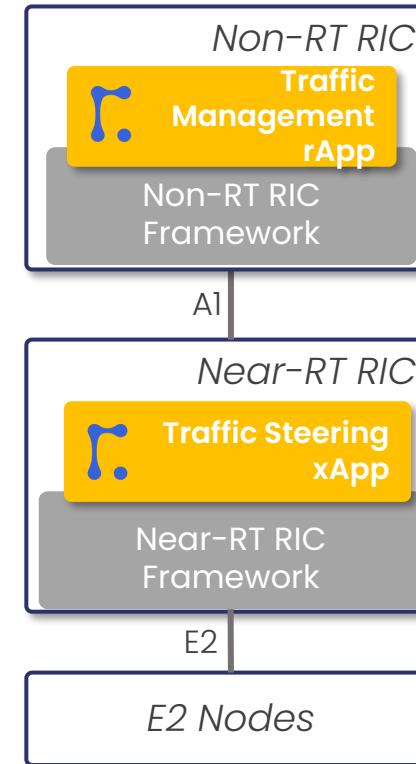

TM-rApp utilizes the enrichment information to derive policies for TS-xApp for advanced V2X scenarios (e.g. emergency, car platoon)

Example Use Cases



Joint optimization of the radio resources

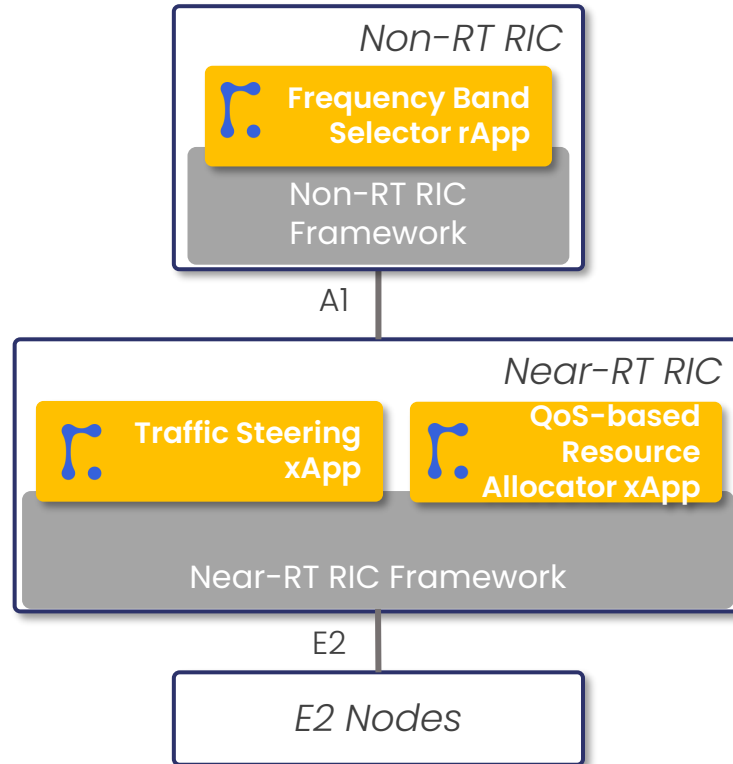

Advanced Traffic Steering operation, with joint optimization of the radio resource utilization. The combined operation of FBS-rApp, TS-xApp, and QRA-xApp.



RAN Security

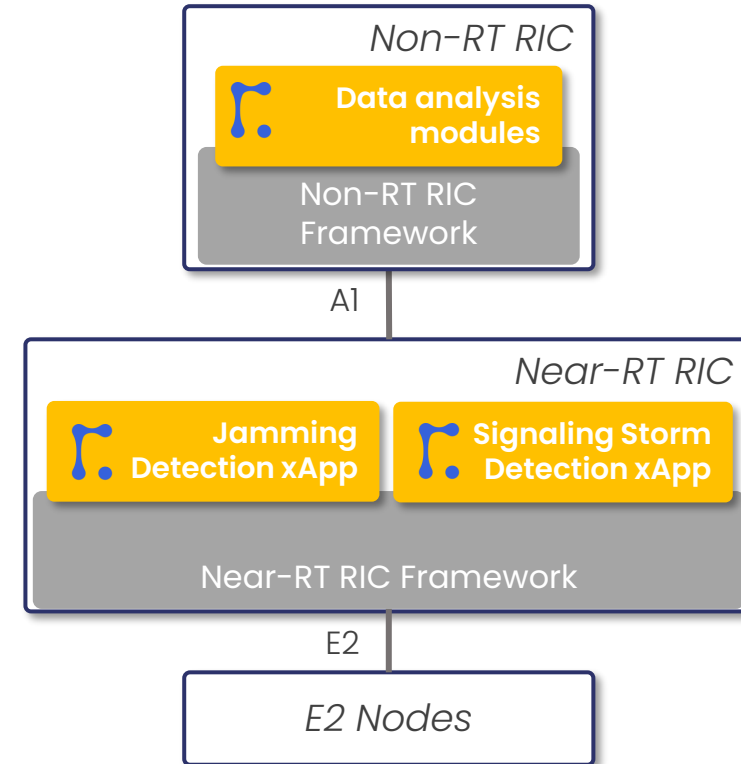

Detection of security threats: jamming and signaling storm at RAN level. The combined operation of JD-xApp, and SSD-xApp supported by data analysis modules in Non-RT RIC.

Traffic Steering Integration Variants



 **Traffic Steering for short-period scenarios**

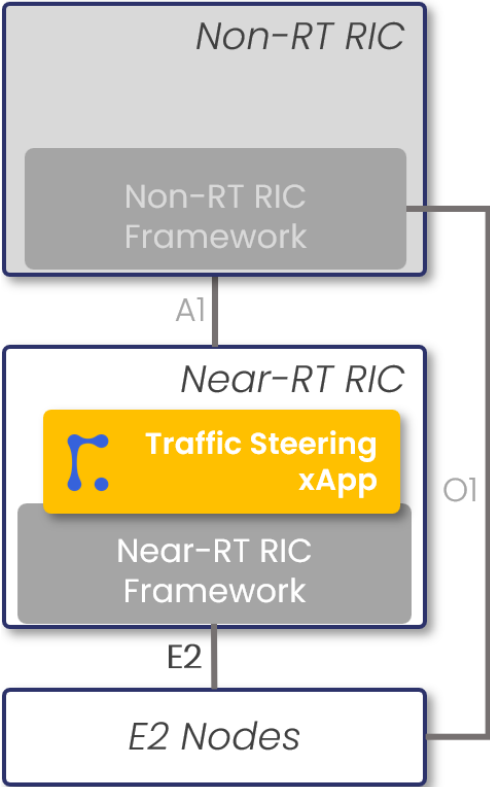

 **Traffic Management for V2X scenarios**

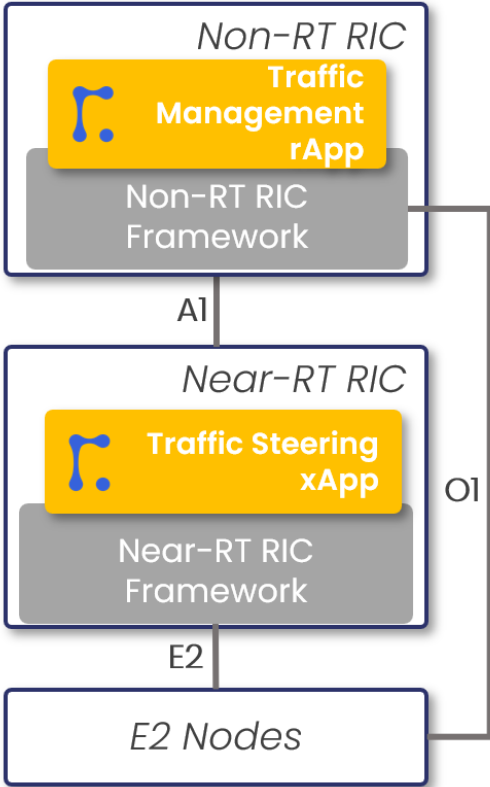

 **Traffic Steering for long-period scenarios**

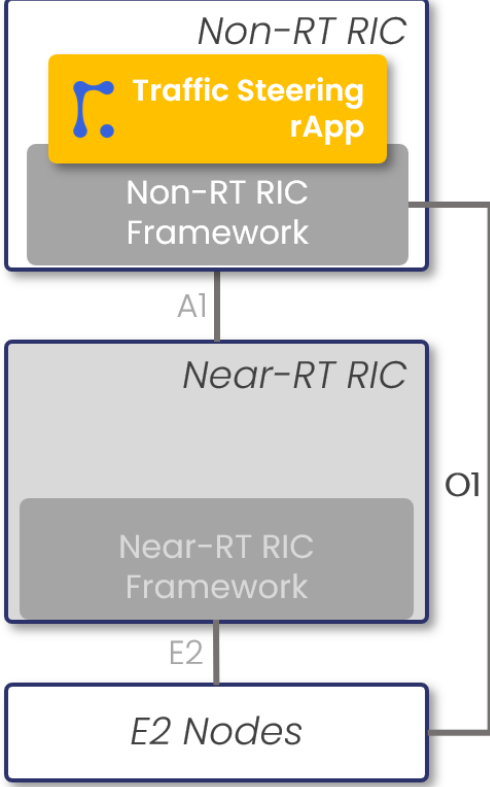



Integrations During O-RAN Plugfests

Rimedo Labs successfully took part in the **O-RAN Global PlugFest Fall 2022** in **i14y Lab** in Berlin.

The demonstrations included **Rimedo Labs Traffic Steering xApp** integration with **VMware's distributed RIC**, and **ONF's SD-RAN micronOS RIC**.



Rimedo Labs successfully took part in the **O-RAN Global PlugFest Spring 2023** in **i14y Lab** in Berlin.

The demonstrations included **Rimedo Labs Energy Saving rApp** control over **Traffic Steering xApp** integrated with **VMware's distributed RIC**.

The conducted tests included **AI policy control**, **energy-saving** and **load-balancing** features, and **coordination** between rApp and xApp.



Rimedo Labs successfully took part in the **O-RAN Global PlugFest Fall 2023** in **i14y Lab** in Berlin, supported by Deutsche Telekom and EANTC and i14y Lab consortium partners.

The demonstrations included:

- **Rimedo Labs' TS-xApp** integrated with **Juniper's Near RT-RIC** and **Keysight's RICTest** emulating E2 Nodes.
- **Rimedo Labs' TM-rApp** control over **TS-xApp** integrated with **VMware's distributed RIC** for advanced V2X scenarios.



Rimedo Labs successfully took part in the **O-RAN Global PlugFest Spring 2025** in the **i14y Lab** in Berlin, supported by **Deutsche Telekom** and **EANTC**, and the **i14y Lab** consortium partners.

Testing included validation of the cooperation between **Rimedo Labs COOS-xApp** and **TS-xApp** deployed in the **Juniper Near-RT RIC** and **Rimedo Labs COOS-rApp** deployed in **Juniper Non-RT RIC** on the energy efficiency optimization task under the network emulated by the **Keysight RICTest** using the data provided by the **Deutsche Telekom**.





Whitepapers

The O-RAN Whitepaper 2026

RAN Automation with SMO and rApps

Recently, the O-RAN automation market has been shifting toward the SMO/Non-RT RIC solutions. At the same time, due to the complexity of current systems, operators demand dynamic, intelligent, context-aware network automation. According to the O-RAN architecture, this can be realized by dedicated rApps residing in SMO/Non-RT RIC, typically utilizing AI/ML tools.

This whitepaper provides an overview of the RAN automation with SMO and rApps. First, the SMO/Non-RT RIC architecture in O-RAN is introduced. It is followed by discussions on two promising use cases of RAN automation: traffic steering and beamforming optimization. The whitepaper addresses both general aspects and the design of related rApps, along with performance results.

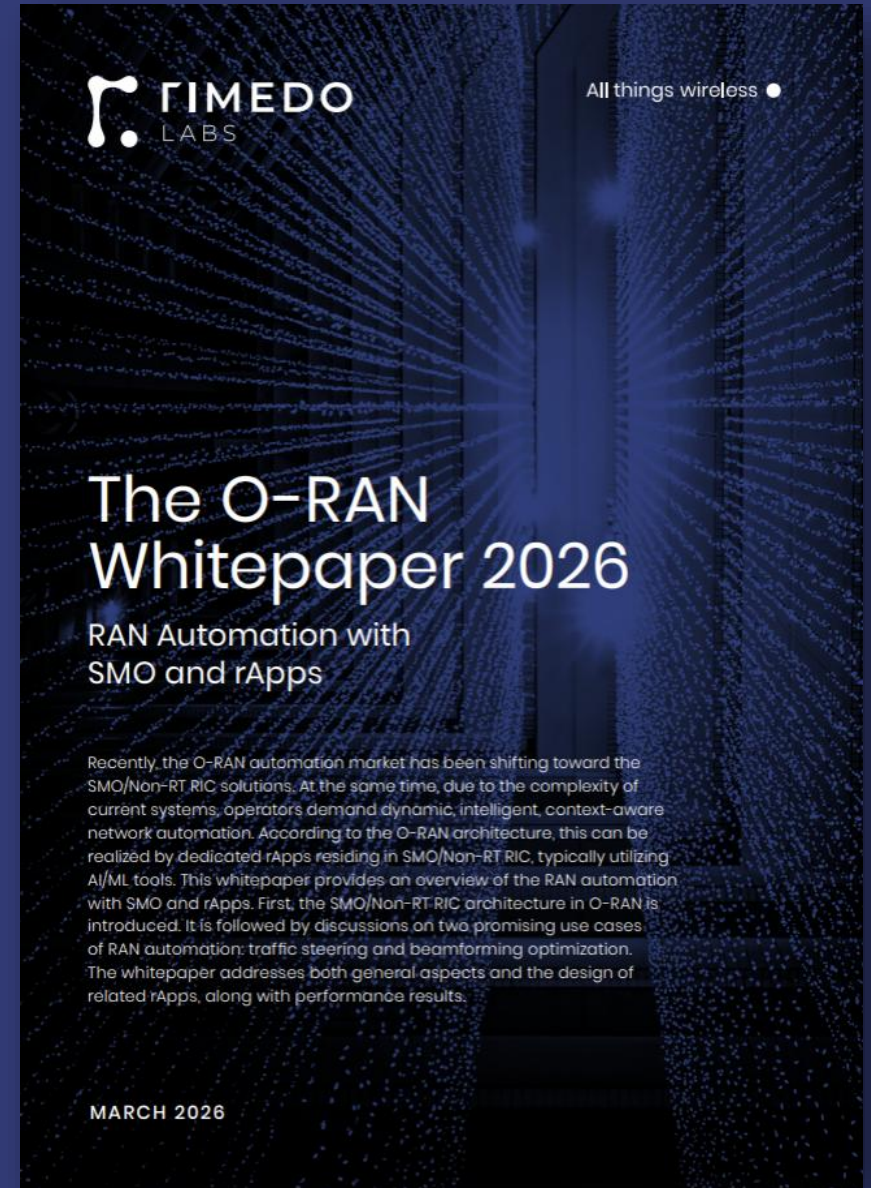

The O-RAN Whitepaper 2024

Traffic Steering in O-RAN

In the current heterogeneous mobile networks, traffic management is considered one of the key features to handle non-uniform user data. To realize this, the traffic steering (TS) function is employed, whose main task is to allocate users' traffic flows to network nodes or cells. O-RAN ALLIANCE provides means to support TS by utilizing RIC frameworks and the accompanied rApps and xApps.

This whitepaper provides an overview of the traffic steering topic in 5G mobile networks and how it fits into the O-RAN area. This is followed up by example implementations of the Traffic Steering xApp and its utilization for various use cases working in tandems with the corresponding rApps for energy saving and V2X scenarios.

The O-RAN Whitepaper 2024

Traffic Steering in O-RAN

In the current heterogeneous mobile networks, traffic management is considered one of the key features to efficiently handle non-uniform user data. To realize this, the traffic steering function is employed, whose main task is to allocate users' traffic flows to network nodes or cells. O-RAN ALLIANCE provides means to support traffic steering through the utilization of Non- and Near-RT RIC frameworks and the accompanied rApps and xApps. This whitepaper provides an overview of the traffic steering topic in 5G mobile networks and how it fits into the O-RAN area. This is followed up by example implementations of the Traffic Steering xApp and its utilization for various use cases working in tandems with the corresponding rApps for energy saving and V2X scenarios.

The O-RAN Whitepaper 2023

Security in O-RAN

Recently, **security** has been pointed out as one of the critical aspects moving forward within the O-RAN domain. Expanded threat surface, as well as specific security challenges and opportunities, have been identified.

This whitepaper provides an **overview of security topics in O-RAN**, specifically in 5G/6G mobile radio networks. We also consider **artificial intelligence** embedded in the network edge as a great tool to support security. We present some **xApps applied to detect and mitigate example attacks**. Conclusions and a discussion on the directions of future developments follow this.

[Download "The O-RAN Whitepaper"](#)

The O-RAN Whitepaper 2023

Security in O-RAN

Recently, security has been pointed out as one of the critical aspects moving forward within the O-RAN domain. Expanded threat surface, as well as specific security challenges and opportunities, have been identified. This whitepaper provides an overview of security topics in O-RAN, specifically in 5G/6G mobile radio networks. We also consider artificial intelligence embedded in the network edge as a great tool to support security. We present some xApps applied to detect and mitigate example attacks. Conclusions and a discussion on the directions of future developments follow this.

AUGUST 2023



The O-RAN Whitepaper 2023

Energy Efficiency in O-RAN

Recently, within the RAN domain, **energy efficiency** has been pointed out as one of the key requirements moving forward. It has been defined as end-to-end involving all domains within the O-RAN system. The overall objective for O-RAN is to gradually become more energy efficient than the regular RAN.

This whitepaper provides an overview of the energy efficiency topic in the O-RAN area. This is followed up by example algorithms utilizing ML schemes and their realization in the form of **rApps based on O-RAN** use cases.

[Download "The O-RAN Whitepaper"](#)

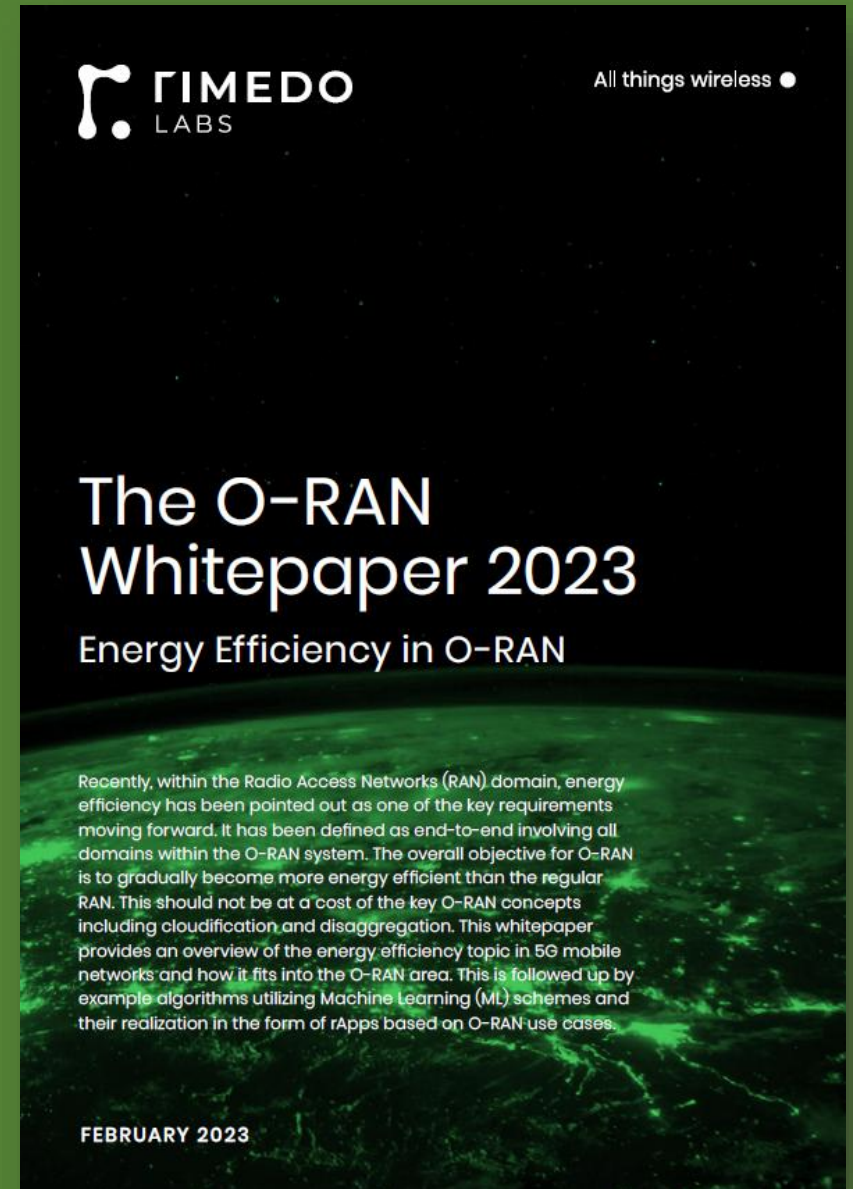

The O-RAN Whitepaper 2022

RAN Intelligent Controller, xApps and rApps

RAN Intelligent Controller (RIC) is one of the key elements in the O-RAN architecture, which allows feeding an „external“ intelligence into the operations of the radio network. It creates a platform for which the software companies could provide per-use case AI-powered algorithms to make way for, among others, radio resources usage, or procedure optimizations.

This whitepaper provides an **overview of the RIC**, discusses its **functional split** into **Non-Real-Time** and **Near-Real-Time** entities along with the concept and examples of **rApps** and **xApps**.

[Download "The O-RAN Whitepaper"](#)

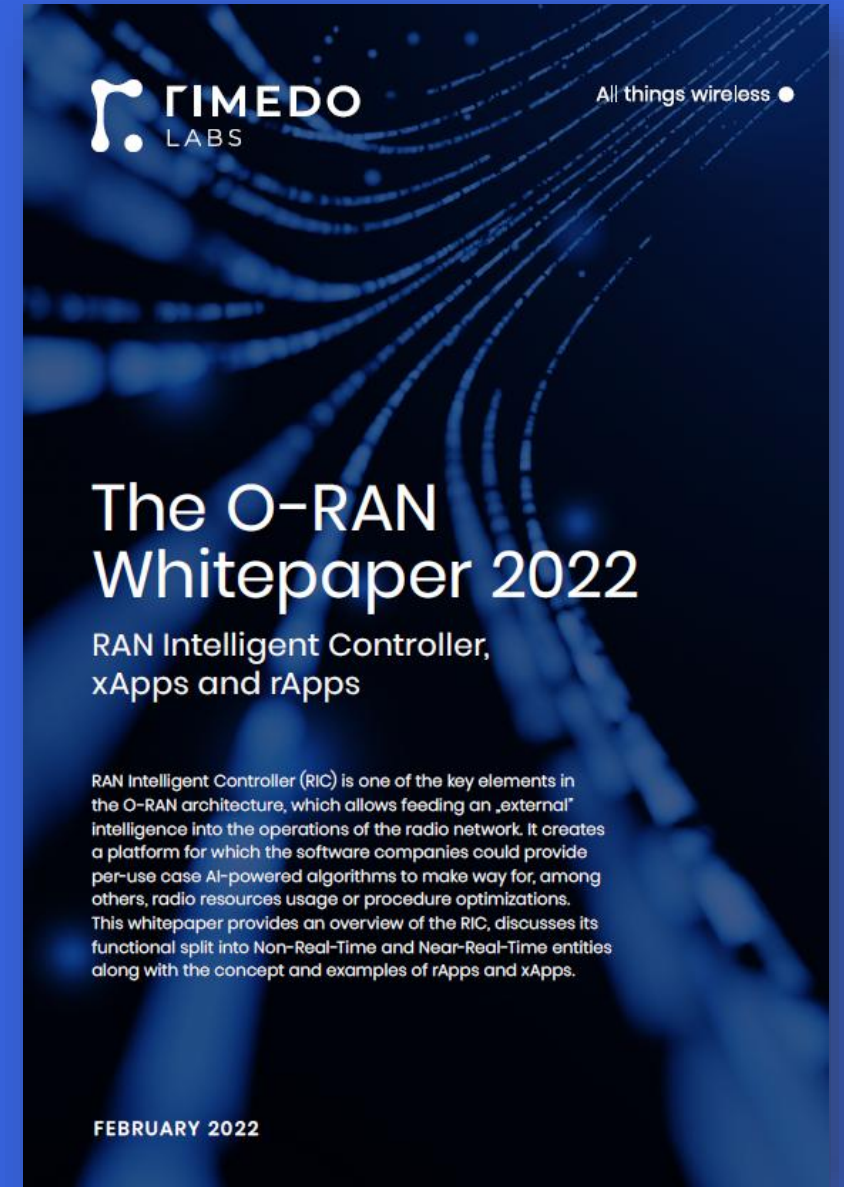

High-quality
consulting,
implementation,
and R&D services
in O-RAN, 5G, 6G,
and AI-RAN.

Let's keep in touch!

Rimedo Sp. z o.o.

ul. Polanka 3

61-131 Poznan, Poland

+48 61 665 38 17

info@rimedolabs.com

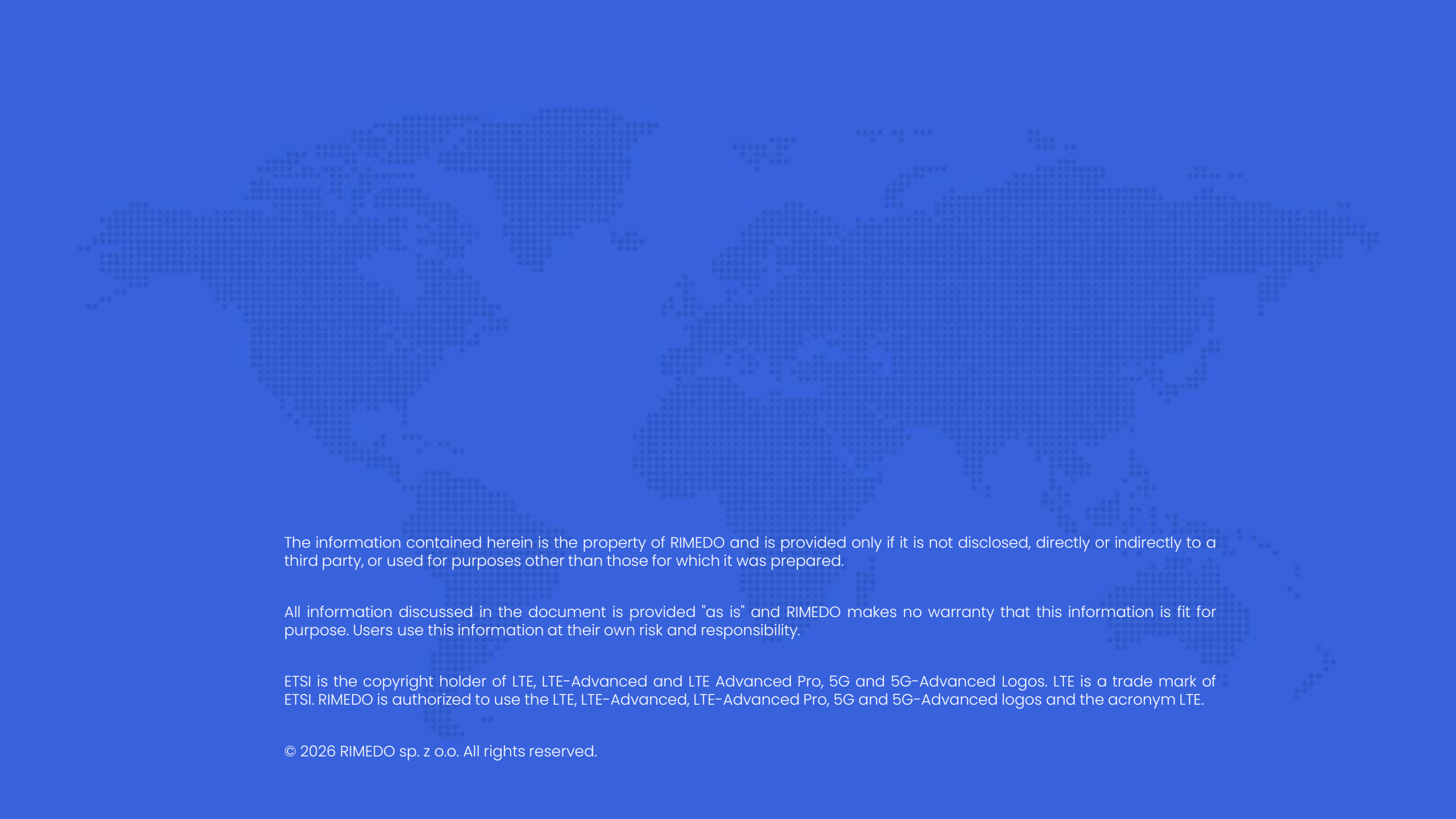

The information contained herein is the property of RIMEDO and is provided only if it is not disclosed, directly or indirectly to a third party, or used for purposes other than those for which it was prepared.

All information discussed in the document is provided "as is" and RIMEDO makes no warranty that this information is fit for purpose. Users use this information at their own risk and responsibility.

ETSI is the copyright holder of LTE, LTE-Advanced and LTE Advanced Pro, 5G and 5G-Advanced Logos. LTE is a trade mark of ETSI. RIMEDO is authorized to use the LTE, LTE-Advanced, LTE-Advanced Pro, 5G and 5G-Advanced logos and the acronym LTE.

© 2026 RIMEDO sp. z o.o. All rights reserved.